

ECE 120: Introduction to Computing

The von Neumann Model

Remember this Figure?

The colors indicate the typical basis for each layer

- human language / theory
- software
- digital hardware

(figure based on
Patt & Patel Ch. 1)

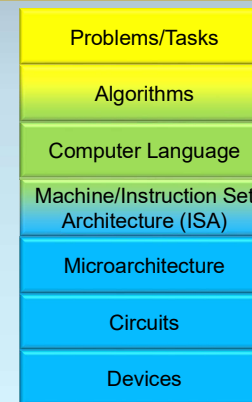

Our Class Builds from the Ground Up

Week #3 (plus ECE220) ↑

You're now ready to understand how a computer works! ↑

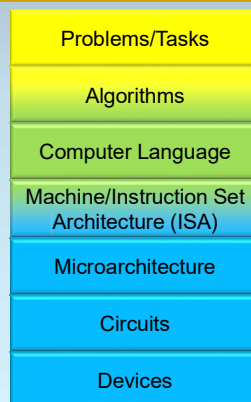

The Central Element of a Computer is an FSM

Microarchitecture
◦ digital hardware
◦ executes instructions from an ISA

The core is an FSM.
We'll cover it briefly, then develop an ISA, then return in detail to microarchitecture.

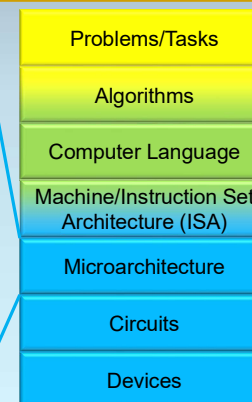

Use the LC-3 ISA as an Example

Machine/Instruction Set Architecture (ISA)

- interface between software and hardware
- examples: x86, ARM, PowerPC

We'll follow Patt & Patel and develop the LC-3 ISA.

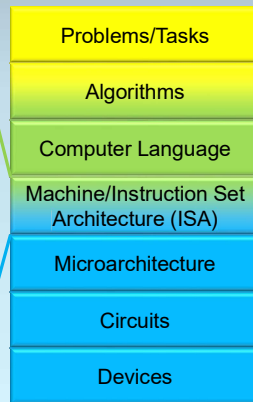

The von Neumann Model Includes a Memory

memory

In 1946, John von Neumann invented

- a **model for computer organization**
- in which a **computer comprises five parts**.

One part is memory:

- The same as you've seen.
- One operation per cycle: read or write.
- The computer's **instructions (program) are stored in the memory**.

The Memory Uses Two Registers: MAR and MDR

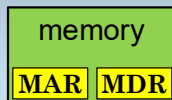

The memory uses two registers to manage data:

- The **Memory Address Register (MAR)** holds the address on which the memory operates (to read or to write).
- The **Memory Data Register (MDR)** holds the bits read from the memory, or the bits to write to the memory.

A Computer Contains a Processing Unit

A computer also contains a processing unit,

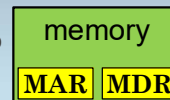

Typical word sizes today are 32 and 64 bits.

which performs all operations.

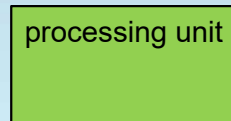

and defines the word size for the computer, the number of bits used in most computations.

The Processing Unit Includes an ALU and a Register File

The processing unit makes use of an **Arithmetic Logic Unit (ALU)** to handle the operations.

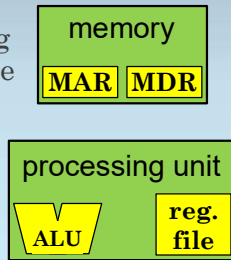

The register file is faster but smaller than memory.

The processing unit also contains a **register file** for temporary storage of values.

The Register File is Fast but Small

The register file contains (surprise!) registers.

Registers use flip-flops and share a clock with the ALU.

Registers are thus

- **faster than SRAM**, and
- **much faster than DRAM** (usually off-chip).

But usually there are **only tens or a hundred registers** (again for speed reasons).

As you might expect, the registers in the register file are named with bits.

Black Arrows Represent Data Moving Amongst Elements

Data moves between the processing unit and memory.

The black arrows represent data.

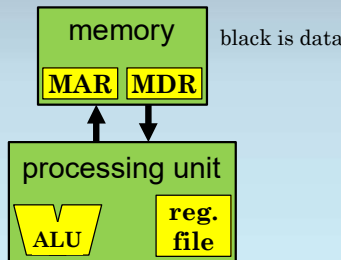

A Computer Needs Methods for Input and Output

A computer also needs the ability to **get input** from outside, and to **deliver results** to the external world.

For example, a keyboard, monitor, mouse, disk, printer, network, and so forth.

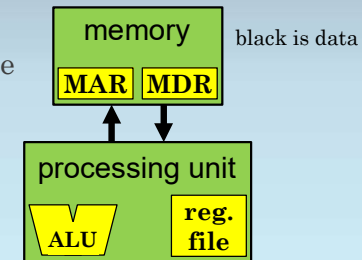

The von Neumann Model Includes Input and Output

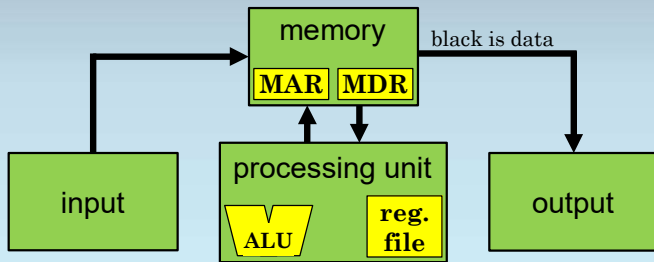

The **von Neumann model includes both input and output.**

The Fifth Element of the von Neumann Model

I said five components, right?

What's missing?

One control unit to rule them all!

The **control unit (an FSM)** uses two registers:

- The **Program Counter (PC)** holds the **address of the next instruction.**
- The **Instruction Register (IR)** holds **the bits** of the current instruction.

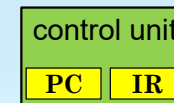

The Control Unit (FSM) Controls All Other Elements

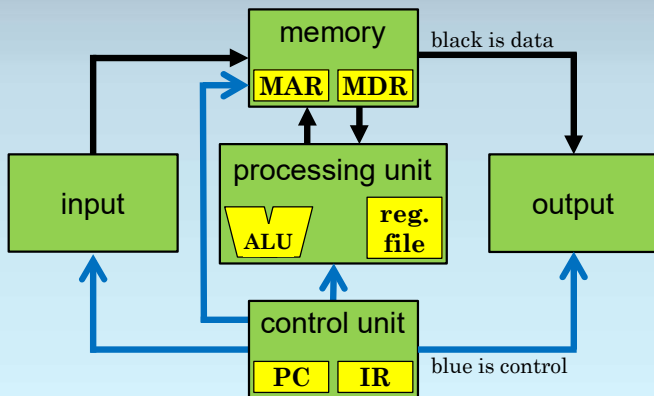

The von Neumann Model Consists of Five Parts

